

NEW MODEL

# FORD TRANSIT 350HD CUTAWAY

Commercial Shuttle Bus

**16**

MAX PASSENGER  
CAPACITY

**11,000**

LBS. GVWR

**23' 6"**

OVERALL  
LENGTH

*Driving Excellence in Specialty Transportation.*

ADA COMPLIANT

FMVSS COMPLIANT

BUILT IN AMERICA

ALTOONA TESTED — 5 YR / 150,000 MI

BODY WARRANTY — 5 YR / 100,000 MI



## CHASSIS & BASE VEHICLE

Chassis Make / Model	Ford Transit Cutaway 350HD
Wheelbase	156"
GVWR	11,000 lbs.
Engine	3.5L EcoBoost V6 or PFDI
Transmission	10-Speed Select Shift Automatic
Fuel Type / Drive	Gasoline / RWD
Infotainment	SYNC 4 w/ 12" Bluetooth Touchscreen

## OVERALL DIMENSIONS

Overall Length	23' 6"
Overall Width (w/o mirrors)	84"
Overall Height (standard roof)	116"
Interior Height (at center)	79.75"
Interior Width (at shoulder)	80.75"
Floor Length	185.5"
Door Opening (W x H)	33" x 81"

## WEIGHTS & CAPACITIES

Average Curb Weight*	8,250 lbs.
GVWR	11,000 lbs.
Average Payload*	2,750 lbs.
Passenger Capacity (Shuttle)	Up to 16 passengers
Passenger Capacity (Ambulatory)	Up to 11 passengers
Wheelchair Positions	Up to 2 WC positions
Fuel Tank Capacity	25 gal

\*Dependent on vehicle configuration, floor plan, and option content



ADA Lift Available (Front and Rear)



Galvanized Steel Cage Structure

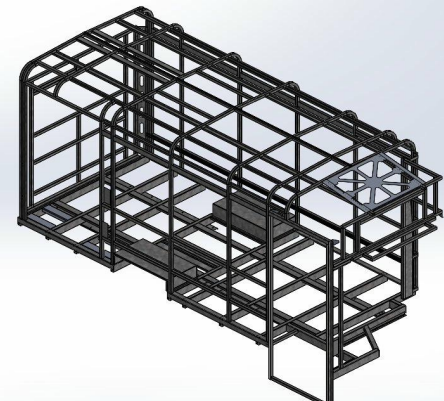

## BODY & STRUCTURE

- Fully Welded 1.5" x 1.5" Tubular Galvanized Steel Roll Cage
- Drive Shaft Loops
- 36" x 36" Clamp Ring Windows w/ sliders
- One Egress Window Per Side
- White High Gloss Fiberglass Gel Coated Exterior Walls & Caps

## FLOORING & INTERIOR

- 5/8" Marine Grade Plywood Floor
- Coved Stepwells and Flooring
- Black Interior Side Walls, White Ceiling
- Grey Padded Soft Touch Vinyl — Driver Area
- Overhead Storage in Front Bulkhead

## SEATING

- Freedman and HSM Commercial Seat Packages

## SAFETY & LIGHTING

- Stanchion at Step Well w/ Modesty Panel & Handrail (Left)
- Right Hand Grab Rail Parallel to Steps
- Electric Powered 36" Entrance Door w/ Dash Switch (33" Clear Opening)
- Door Auto-Disables at 5 MPH
- Door-Activated Interior Lights
- Interior LED Lighting Package
- Exterior LED Lighting Package
- 4 Interior Speakers (2 Front, 2 Rear)
- Emergency Triangles

## ELECTRICAL & MISC.

- Color Coded Wiring w/ printed circuit IDs
- Intermotive Flextech Programmable Electrical System
- Endera Decal Package
- Rear Mud Flaps & Wheel Fender Guard
- Steel Rear Bumper
- Rosco Exterior Manual Mirrors
- Weight Slip, Leak Test, PDI Checklist Included



REAR 3/4 VIEW — ADA ACCESSIBLE

## COMPLIANCE & WARRANTY

### Federal/State:

ADA & FMVSS Compliant

### Altoona Tested:

5 Year / 150,000-Mile Altoona Tested

### Structural Body:

5 Year / 100,000-Mile Warranty

### Ford Powertrain:

5 Year / 60,000-Mile Warranty

### Corrosion Coverage:

5 Year / Unlimited Miles

Proudly Designed, Engineered &  
Built in Ottawa, Ohio, USA